

Guide to deploying DGT probes in sediments

This is a general guide for deploying DGT devices in sediments. It is designed to complement and to be used with the individual guides for each probe type and set of analytes. Those guides are written primarily for deployments in solution. However, once the binding gel is retrieved from the device the subsequent elution and analysis procedures are virtually the same and so those procedures, which are specific to the analysis are not duplicated here.

General considerations

Deployment time

After a maximum reached within a few hours, the flux to a DGT device deployed in a soil or sediment will progressively decline as the analyte adjacent to the device is consumed. If the requirement is to calculate concentration, a deployment of 1 day is appropriate. Longer deployment times up to three days may, however, be appropriate in some circumstances. For example, if trace metals are strongly complexed by humic substances, the slower diffusion of these complexes delays the time to maximum flux. Deployment of 3 days will ensure that this slower approach to a pseudo steady state negligibly affects the measurement. When probes are inserted into sediments there will inevitably be a small temporary disturbance of the spatial distribution of analyte. This spatial structure is rapidly restored through the strong redox buffering mechanisms. However, if there is a desire to measure metals at high spatial resolution in sediments or soils, leaving the probes in place for longer than 1 day will allow better establishment of the structure and minimise the effect of the initial disturbance on the time-averaged measured flux. If one of the analytes has an exceptionally high concentration, such as near mM concentrations of Fe in anoxic sediments, binding of weakly binding Mn can be affected if deployments exceed a day.

Storage

Store the DGT devices in a refrigerator (4°C). The DGT devices are provided in sealed clean plastic bags containing a few drops of 0.01M NaNO₃ (or 0.01M NaCl) solution. Do not open them during storage. Check the devices occasionally to make sure they are under moist conditions. Add a few more drops of trace metal clean 0.01M NaNO₃ (or 0.01M NaCl) solution if it is necessary. Do not freeze the devices, as performance could be affected.

Handling

The main consideration when using DGT devices is to prevent contamination of the sample. Clean handling procedures should be adopted during deployment and recovery of the DGT devices and all subsequent handling during the sample treatment step. Do not touch or contact the white filter membrane at the face of the probe. In general, the highest quality reagents should be used and all equipment and laboratory apparatus cleaned appropriately.

Deoxygenation

Deoxygenation of the DGT probes is not so straightforward because it will only be effective if the transfer of the DGT probes from their deoxygenation solution to the sediment can be done within no more than a few 10s of seconds. Exposure of the probe to the air for longer times will quickly replenish the oxygen, as demonstrated in Davison et al (1994). However, whether it will be necessary will depend on individual circumstances. Because the DGT assembly is thin it does not contain a lot of oxygen and, within a short period of time, (say 30 minutes) the oxygen diffusing out into the sediment and electron donors diffusing into the gels will consume the oxygen within the DGT gels. Clearly this will compromise the DGT measurement of redox sensitive and secondary affected components (e. g. trace metals) within this 30 minute time period of initial accumulation. However, DGT is usually deployed for times in excess of a day. Therefore, this initial period where the presence of oxygen can have an effect on the DGT accumulation will only represent at most about 2% of the total accumulation time. Consequently the effect on the DGT measurement is likely to be negligible. There is an urgent need for work to be done to verify experimentally the effect of preliminary deoxygenation on DGT measurements and whether it is necessary.

DGT Research Ltd

Skelmorlie, Bay Horse Rd, Quernmore, Lancaster, Lancashire, LA2 0QJ
Phone : +44 (1524) 593899, 2nd Phone : 01524 751451
Email : info@dgtresearch.com

General deployment considerations

Biofouling: Biofouling is not a problem for deployments in sediments, but could affect the part of the probe in the overlying water. The extent of any biofouling is very dependent on local conditions, particularly light, temperature and productivity. Biofouling is not usually a problem for deployments less than a week.

Deploying DGT devices

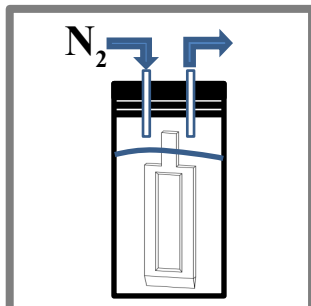

1. If probes are to be deoxygenated include this step, otherwise proceed directly to step 2. Immerse the DGT probe for 24 h in a clean container filled with 0.03 M NaCl solution through which N₂ is steadily bubbled. Seal this container to maintain it oxygen-free for transportation to the deployment site (ideally no more than a few hours).

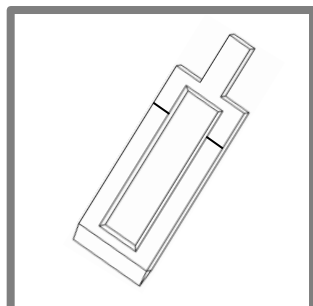

2. Remove the probe from either the oxygen-free container or its supplied plastic bag. Quickly mark the plastic body of the probe (permanent marker) at the intended depth for the sediment-water interface.

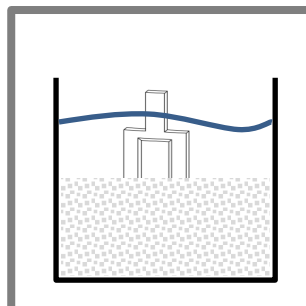

3. As soon as possible (within seconds) of removing the probe from its oxygen-free environment, smoothly push it into the sediment until the mark is in line with the sediment-water interface. Keep the probe as vertical as possible during the insertion.

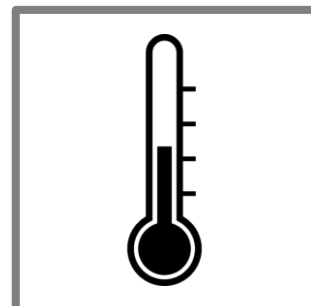

4. Accurately record the temperature during the deployment period. If the variation is within $\pm 2^\circ\text{C}$ a mean (or start and end temperature) will suffice. If the variation is greater, ideally the mean temperature should be obtained from an integrated record of temperature (data logger).

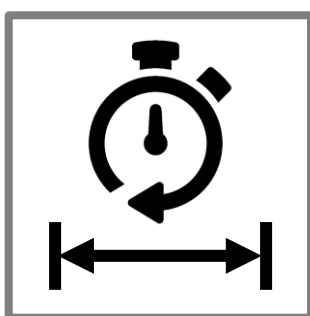

5. Provide an accurate record to the nearest minute of the deployment time

DGT Research Ltd

Skelmorlie, Bay Horse Rd, Quernmore, Lancaster, Lancashire, LA2 0QJ
Phone : +44 (1524) 593899, 2nd Phone : 01524 751451
Email : info@dgtresearch.com

Procedure for analyzing DGT samples

DGT Recovery and Sample Treatment

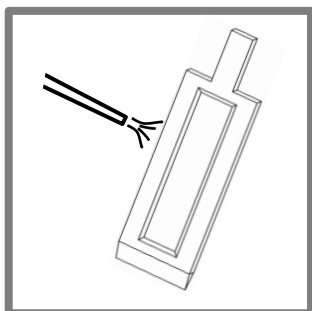

1. After retrieving the DGT device from the deployment environment thoroughly rinse the DGT probe with ultrapure water from a wash bottle.

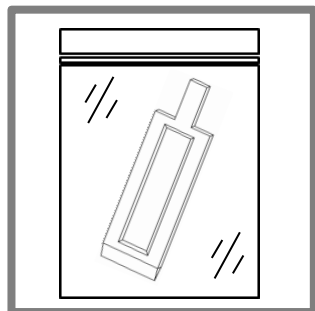

2. Place in a clean plastic bag for storage and transportation back to the lab for sample treatment.

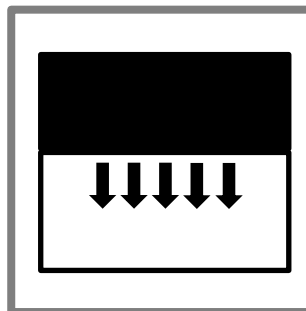

3. For analytes at trace concentrations, all sample treatment should be carried out in a laminar flow hood to avoid contaminating the sample.

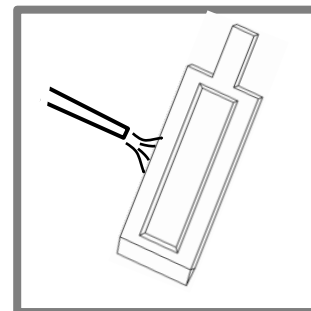

4. Remove from the plastic bag and thoroughly rinse the device with ultrapure water.

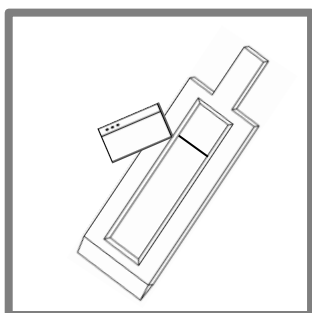

5. To mark the gel position, make a small cut through the filter and gel layers at the sediment/water interface mark using a Teflon coated blade. Then, cut the gels and the filter membranes along the window edges without disassembling the probe.

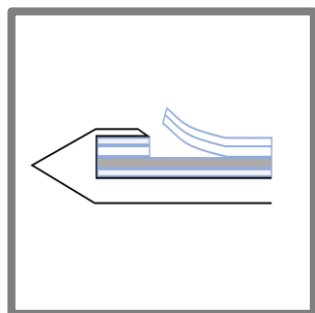

6. Remove the top filter membrane and the diffusive gel.

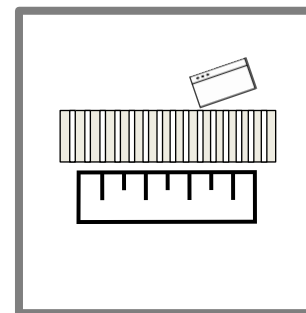

7. Carefully lift the resin gel together with the bottom filter membrane out of the window and lay them alongside an acid cleaned plastic ruler on a clean flat surface. Cut the resin gel at the resolution required (no less than 1 mm).

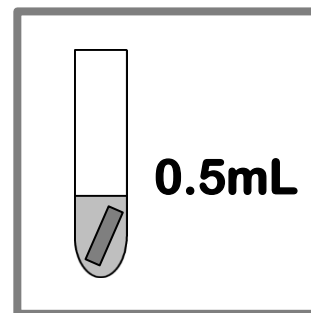

8. Put each gel strip into a centrifuge micro tube (0.5ml or 1.5 ml) and add the appropriate elution solution. The exact procedure for each probe type and analyte should then be followed.

Calculation

The mass, M , of analyte accumulated on the slice of binding layer eluted, of volume, V^{bl} , is calculated from the measured concentration of analyte, c_e , in the eluent, of initial volume V_e , remembering to take into account any subsequent dilution.

$$M = \frac{c_e(V^{bl} + V_e)}{f_e}$$

Where c_e is in nmol mL^{-1} or ng mL^{-1} , and V^{bl} and V_e are in mL, M is in nmol or ng.

This mass can be used to calculate the mean flux from the sediment to the DGT slice of gel, of area A_p , in the device for the deployment time, t (in seconds).

DGT Research Ltd

Skelmorlie, Bay Horse Rd, Quernmore, Lancaster, Lancashire, LA2 0QJ
Phone : +44 (1524) 593899, 2nd Phone : 01524 751451
Email : info@dgtresearch.com

$$F = M / A_p t$$

The DGT equation can be used to calculate the mean concentration at the surface of the device during the deployment time.

$$C_{DGT} = \frac{M \Delta_g}{D^{mdl} A_p t}$$

Δ_g (also known as δ_g) (usually 0.094 cm) is the total thickness of the materials in the diffusion layer (diffusive gel and filter membrane).

D^{mdl} ($\text{cm}^2 \text{s}^{-1}$) is the diffusion coefficient of analyte in the material diffusion layer (diffusive gel and filter membrane) for the deployment temperature (see [diffusion coefficients](#)).

Use the recommended units shown above to facilitate easy calculation.

A key consideration is the meaning of C_{DGT} . Because DGT continually removes analyte, its concentration at the surface of the DGT device may be lowered during the course of the deployment. In some sediments the analyte may be continually resupplied to solution from the solid phase. When this effective buffering is substantial, the measured C_{DGT} is close to the concentration in the porewaters, C_{pw} , at the same location. Comparison of C_{DGT} with C_{pw} can provide information on the dynamics of analyte exchange between porewater and solid phase. A detailed account of the dynamic processes existing when DGT is deployed in sediments can be found in Chapter 7 of the DGT book (see reference below). Note that spatially resolved concentration maxima in porewater concentrations are faithfully represented by DGT (Sochaczewski et al, 2009).

References

Diffusive Gradients in Thin-Films for Environmental Measurements, Ed. W. Davison, Cambridge University Press, 2016, Cambridge. Chapters in this book, which are particularly relevant are:

1. Introduction to DGT (covers the basic principles)
William Davison and Hao Zhang
2. Principles of measurements in simple solutions (explains procedures for calculations)
William Davison and Hao Zhang
3. Diffusion layer properties (provides and critiques diffusion coefficients)
William Davison and Hao Zhang
4. Binding layer properties (provides properties including elution efficiencies for a range of binding agents and analytes)
William W. Bennett, Maja Arsic, Jared G. Panther, David T. Welsh, and Peter R. Teasdale
7. Principles and applications in soils and sediments (considers the equations and models describing the dynamics)
Nik Lehto
8. Measurement at high spatial resolution (describes the evolution and recent developments of high resolution measurements in 1 and 2D)
Jakob Santner and Paul N. Williams
10. Practicalities of working with DGT (practical issues such as deployment, quality control and sensitivity)
Dianne F. Jolley, Sean Mason, Yue Gao and Hao Zhang

Prime publications for sediments:

- W. Davison, H. Zhang and G. W. Grime, Performance characteristics of gel probes used for measuring the chemistry of porewaters, *Environ. Sci. Technol.* **28**: (1994), 1623-1632.
- L. Sochaczewski, W. Davison, H. Zhang and W. Tych, Understanding small scale features in DGT measurements in sediments, *Environ. Chem.* **6**: (2009), 477-485.
- M. Harper, W. Davison, H. Zhang, H. and W. Tych, Solid phase to solution kinetics in sediments and soils interpreted from DGT measured fluxes, *Geochim. Cosmochim. Acta.* **62**: (1998), 2757-2770.
- G. R. Fones, W. Davison, and J. Hamilton-Taylor, (2004) The fine scale remobilisation of metals in the surface sediment of the North East Atlantic. *Cont. Shelf Res.*, **24**: (2004), 1485-1504.
- N. J. Lehto, M. Larsen, H. Zhang, R. N. Glud, W. Davison, A mesocosm study of oxygen and trace metal dynamics in sediment microniches of reactive organic material, *Sci. Rep.* **7**: (2017).

DGT Research Ltd

Skelmorlie, Bay Horse Rd, Quernmore, Lancaster, Lancashire, LA2 0QJ
Phone : +44 (1524) 593899, 2nd Phone : 01524 751451
Email : info@dgtresearch.com